

# SIGNALBOOST™ DT™ DESKTOP



## SIGNALBOOST™ DT Dual-Band Cellular/PCS Amplifier System Installation Guide



### Contents:

Before Getting Started . . . . .	1
Package Contents . . . . .	1
Tools Required for Installation . . . . .	1
How It Works . . . . .	2
Reasons for Weak Cellular Signals . . . . .	2
First Step: Find the Strongest Signal . . . . .	3
Installation Options - Cradle Antenna . . . . .	3
Antenna Placement . . . . .	4
Antenna Separation . . . . .	5
Installing the Cradle Antenna . . . . .	6
Installing the Amplifier Unit . . . . .	9
Powering Up the Amplifier . . . . .	10
Understanding the Indicator Light . . . . .	10
Warnings and Recommendations . . . . .	11
Frequently Asked Questions . . . . .	11
Amplifier Specifications . . . . .	13
Guarantee and Warranty . . . . .	14

## Welcome to the Wilson Electronics Family of Products!

Thank you for purchasing the Wilson SignalBoost DT amplifier system. You are just minutes away from enjoying improved performance from your cellular phone and/or laptop data card. When installed properly, the SignalBoost DT will significantly reduce dropped calls and improve both voice and data signal quality. By taking a few minutes to read and follow the simple instructions in this guide, you will get the most out of your new amplifier system. If you have questions during or after installation, please don't hesitate to contact a member of our Technical Support team by phone (866-294-1660 or 435-673-5021) or email (tech@wilsonelectronics.com). We're here to help!

### Before Getting Started

This guide will help you properly install Wilson's SignalBoost DT. **It is recommended that you read through all of the installation steps and familiarize yourself with the product.** Read the instructions and visualize where you want to place the components before mounting any equipment. If you do not understand the instructions in full, please contact Wilson Technical Support at 866-294-1660 or 435-673-5021.

### Inside this Package:



SignalBoost DT  
Amplifier



On-board  
Antenna



Antenna and Cradle  
(locate outside on pole,  
wall, or inside on window)



Coaxial Cables  
(20 and 30 feet)



Cable  
Connector



Amplifier  
Wall Bracket



Pole-Mount  
(Packet A)



Wall-Mount  
(Packet B)



Window-Mount  
(Packet C)



AC Power  
Supply

### Tools Required for Installation:

Depending on your particular installation, you will need the following tools:

- Window-mount - No additional tools needed
- Wall-mount - Drill and 3/16-inch bit, Phillips-head screwdriver
- Pole-mount - 1/4-inch open-end wrench or adjustable wrench

## How it Works

Your Wilson SignalBoost DT Amplifier works by picking up a stronger signal from an antenna mounted on a pole or wall outside your building or high on a window inside your building, facing the cell site. The amplifier then increases the signal and transmits it through the on-board antenna on the amplifier to your cell phone or laptop data card.

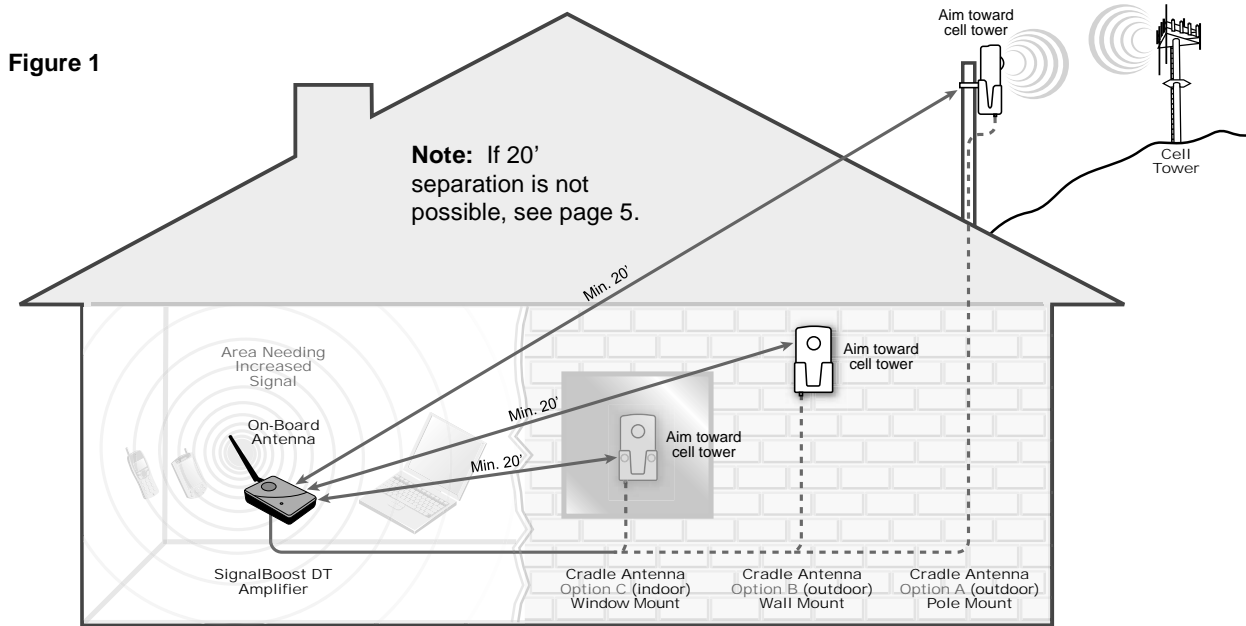

## Reasons for Weak Cellular Signals

Anyone who uses a cell phone or cellular data card knows the frustration of not being able to connect to or maintain a strong cellular signal. When this occurs, it's generally due to one of two reasons:

1. Location of the Nearest Cell Tower – Cell towers are situated to provide broad coverage; however, there are many areas in which signal strength may be reduced by topographic features or by local government restrictions on the height or placement of the towers themselves. Rural areas generally have fewer cell towers than urban regions.
2. Natural and Man-made Obstructions – Signal strength can also be negatively affected by trees, hills, buildings and other obstructions. You may be relatively close to a cell tower but still unable to make a call. This often occurs in homes, offices and other buildings in which stucco, concrete or metal walls block the signal.

The SignalBoost DT works with two antennas (included). The on-board antenna communicates with your cell phone or laptop data card, and the cradle antenna communicates with the cell tower. The cradle antenna is designed for installation outside on a wall or a pole, or inside on a window or wall, depending on your preferred configuration (see Figure 1).

The cradle antenna receives the outside signal and sends it through the coax cable to the SignalBoost DT, where it is amplified and retransmitted much more strongly through the on-board antenna into the room. When the on-board antenna picks up a signal from your cell phone or data card, the amplifier boosts that signal and transmits it through the cable to the cradle antenna and back to the cell site. (Note: the SignalBoost DT will only operate if there is adequate signal to amplify.)

## First Step: Find the Strongest Signal

Before you install your SignalBoost DT, it is very important that you determine the location of the best available cellular signal. This will affect where you place the cradle antenna and will help you get the best performance from your system.

You will find the strongest signal outside your house or building, at the highest place available. Your cell phone can help you find the strongest outside signal, using any or all of the following methods:

1. Place calls from several locations outside your building and note where you get the best reception.
2. Check the bar indicator on your cell phone display and note where the signal appears to be the strongest. Note: cell phone bars are only an approximation of signal strength and vary from phone to phone. They can take up to 30 seconds to reset to a new reading. Be patient and repeat your signal check several times.
3. Some cell phones have test modes for reading accurate signal strength. Using the test mode on your cell phone, move around the outside of your building and determine the location of the strongest signal. (For assistance with the test mode on your particular phone, visit the Technical Support section of our website: [www.wilsonelectronics.com](http://www.wilsonelectronics.com) or call our Technical Support Department at 866-294-1660 or 435-673-5021).

Once you have determined where the outside signal is strongest, you should plan to install the cradle antenna in that general area, either outside or inside. (See the following section for alternative installation options).

## Installation Options - Cradle Antenna

The cradle antenna is directional – it receives and transmits best in one direction. The round Wilson insignia indicates the side of the antenna that should face toward the cell site when the unit is placed in the cradle.

Note: the weaker the signal is at the cradle antenna, the shorter the distance the on-board antenna will transmit; therefore, signal strength at the cradle antenna is extremely important. The SignalBoost DT comes with all necessary parts for installation of the cradle antenna in three alternative locations (see Figure 2):

- Outside on a pole (bracket, nuts and washers)
- Outside on a wall (screws, washers and anchors)
- Inside on a window or wall (suction cups or double-sided adhesive strip)

Figure 2

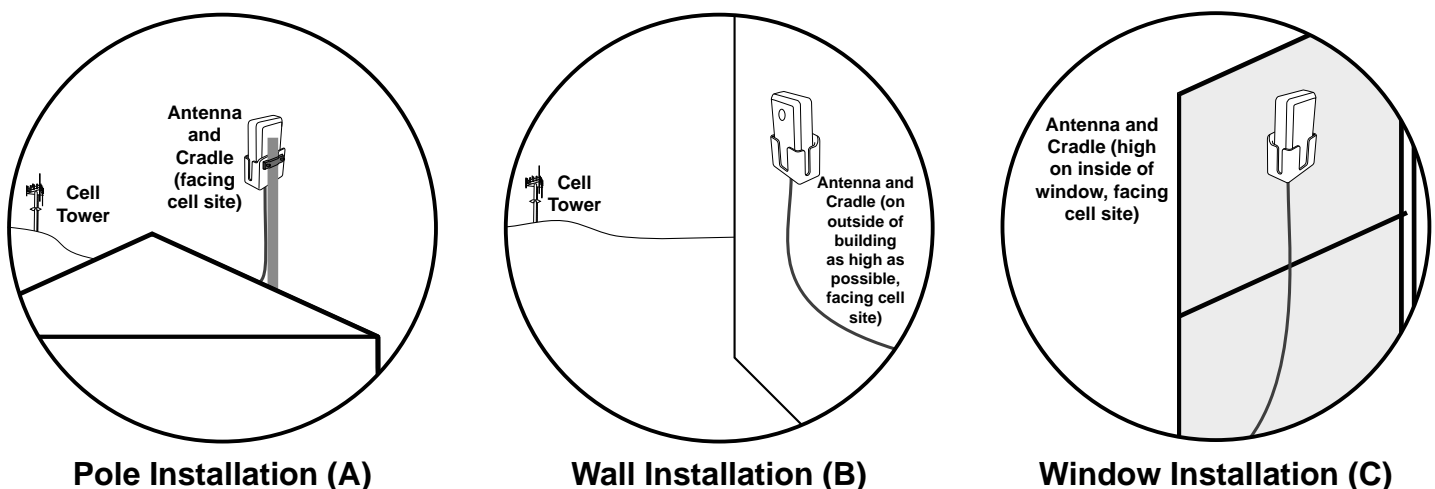

If you have access to the roof or to the outside walls of your house or building, your best choice is to place the cradle antenna outside, facing toward the cell site (see page 3). If you cannot access these areas, use your cell phone and find an area indoors that faces the cell site, ideally near the top of a window or wall, where you can make calls or you have several bars on your phone. Usually, a window is preferable to a wall, because it does not obstruct radio waves. **Note:** install the antenna as high as possible on the window or wall for the strongest signal. If you cannot find an indoor location with a good signal position, you will need to install the cradle antenna outside on a wall or pole, and turn it toward the cell site.

## Antenna Placement

The location of the amplifier with its on-board antenna in relation to the cradle antenna is very important. Once you find a good signal location for the cradle antenna, the amplifier and on-board antenna need to be located *behind it* to reduce the possibility of oscillation (indicated by a red indicator light on the amplifier). In other words, the front of the cradle antenna (indicated by the Wilson insignia) needs to face in the direction of the cell site and not in the direction of the amplifier and on-board antenna (see Figure 3).

Figure 3

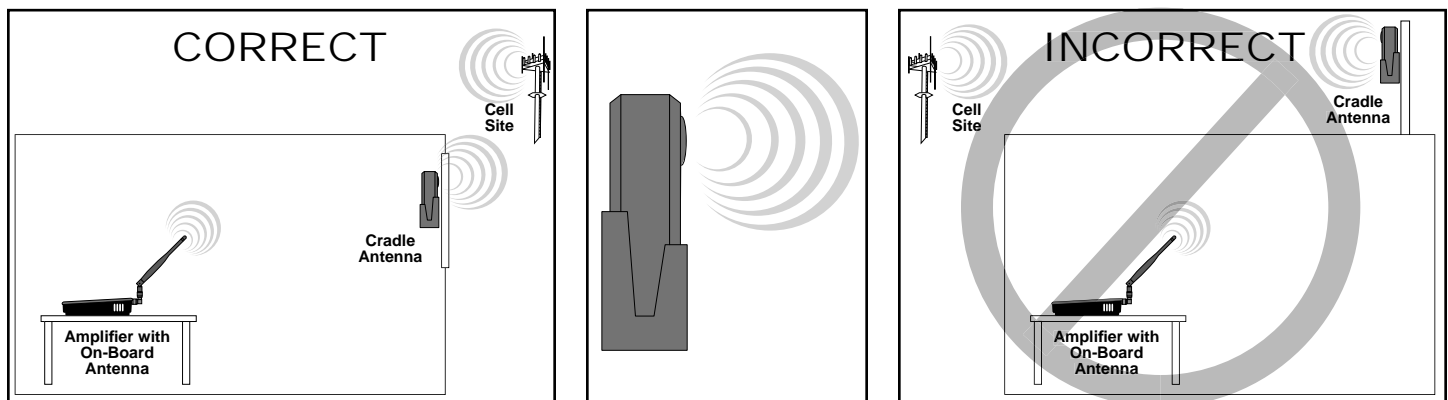

Position the on-board antenna at a 45-degree angle by adjusting it on its base. Note: it may also be positioned vertically; however, this will require greater separation from the cradle antenna (see Page 5).

The Wilson insignia on the cradle antenna should face **toward** the cell site and **away from** the on-board antenna.

Never point the cradle antenna across the building toward the on-board antenna. Do not let the cradle antenna and the on-board antenna transmit toward each other.

In addition, it is important that the on-board antenna be positioned behind, and not over, the amplifier, as shown below.

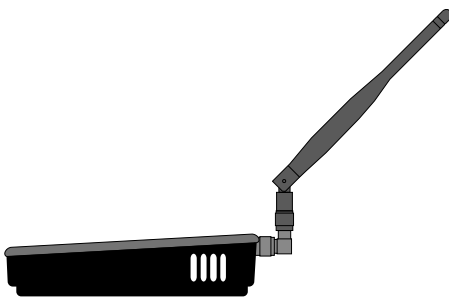

CORRECT



INCORRECT

## Antenna Separation

The distance between the cradle antenna and the amplifier with the on-board antenna is extremely important! If they are too close together, they will oscillate, causing the system to shut down, as indicated by a red light on the amplifier. It is very important to keep the distance between the two units at least 20 feet (30 or 40 feet is even better). (See Figure 4) Depending on your specific installation, you may need the 20-foot coax cable, the 30-foot cable, or both cables connected with the supplied barrel connector.

Figure 4

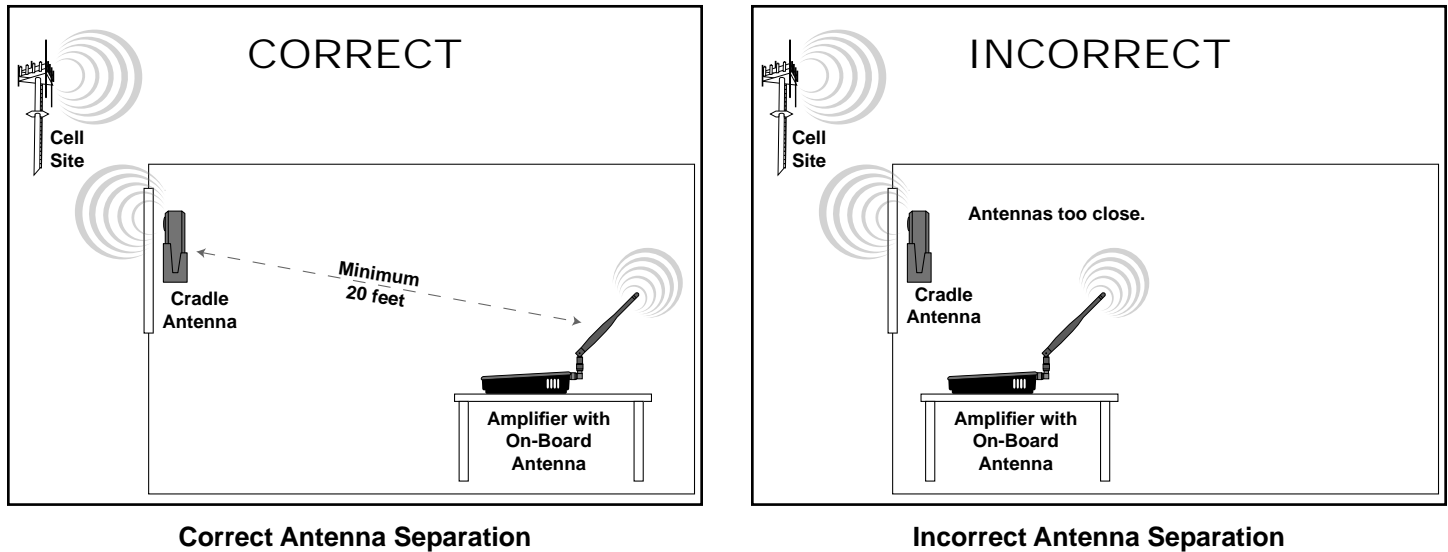

Even at 20 feet, the amplifier may shut down, as indicated by the red light. By moving the on-board antenna to a horizontal position, you may be able to change the red light to a green light, indicating that the system is operating properly (see Figure 5).

Figure 5

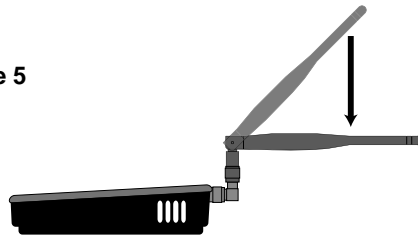

If you are unable to maintain the 20-foot minimum separation between antennas, it may be possible to achieve normal operation (a green light) at less than 20 feet by moving the on-board antenna to a horizontal position, as noted above, and rotating the on-board antenna in relation to the cradle antenna (see Figure 6). Do not position the on-board antenna over the amplifier unit.

Figure 6

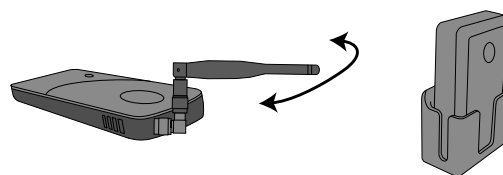

If you are not able to change the red light to green in this manner, more separation is needed between the cradle antenna and the on-board antenna.

## Installing the Cradle Antenna

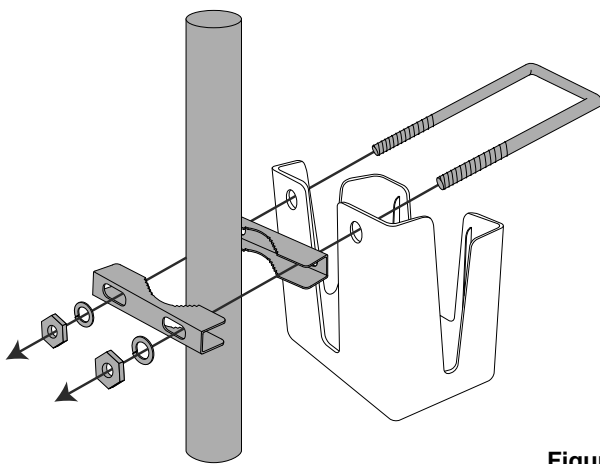
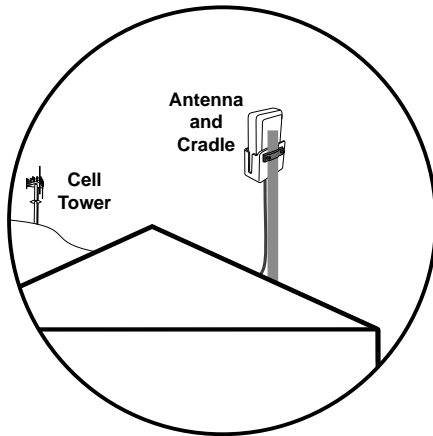

Figure 7



Coax  
Cable



Cable  
Connector

### Outside Pole Mount (Packet A)

1. The supplied pole-mount bracket is designed to accommodate a pole diameter of 1 to 2 inches. Install the pole in the desired location using your own hardware.



**Warning: RF Safety:** The cradle antenna, when used with the included cable, must have a separation distance of at least 8 inches from all persons. If the cable is shortened, or if a different type of cable is used, or if a different antenna is used, consult with Wilson Technical Support to verify that the planned installation is safe. Call 866-294-1660 or 435-673-5021, or email [tech@wilsonelectronics.com](mailto:tech@wilsonelectronics.com).



**Warning:** Take care to ensure that neither you nor the pole comes near any power lines during installation.

2. Insert the supplied U-bolt through the holes in the cradle and slide one half of the bracket assembly onto the U-bolt (see Figure 7).
3. Fitting the assembly onto the pole, slide the second half of the bracket onto the U-bolt and secure it with lock washers and nuts. Be sure the cradle is at the desired height on the pole and is rotated toward the nearest cell tower before tightening the nuts. (Do not over-tighten the nuts.)
4. Insert the antenna into the cradle **with the Wilson insignia facing in the direction of the cell tower**. The cable connection should protrude through the bottom of the cradle.
5. Connect the supplied coax cable to the antenna. Route the cable as desired to where the amplifier will be located. Depending on the distance between the amplifier and antenna, you may need one or both lengths of the supplied cable. If you use both, connect them together with the supplied cable connector.

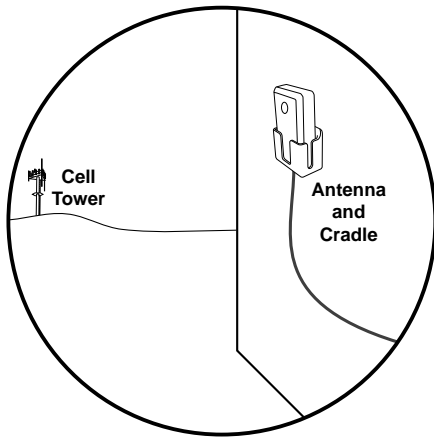

## Outside Wall Mount (Packet B)

1. Select a location on an outside wall as high as possible and at least 20 feet away from where the amplifier will be located (see Figure 8).



**Warning: RF Safety:** The cradle antenna, when used with the included cable, must have a separation distance of at least 8 inches from all persons. If the cable is shortened, or if a different type of cable is used, or if a different antenna is used, consult with Wilson Technical Support to verify that the planned installation is safe. Call 866-294-1660 or 435-673-5021, or email [tech@wilsonelectronics.com](mailto:tech@wilsonelectronics.com).

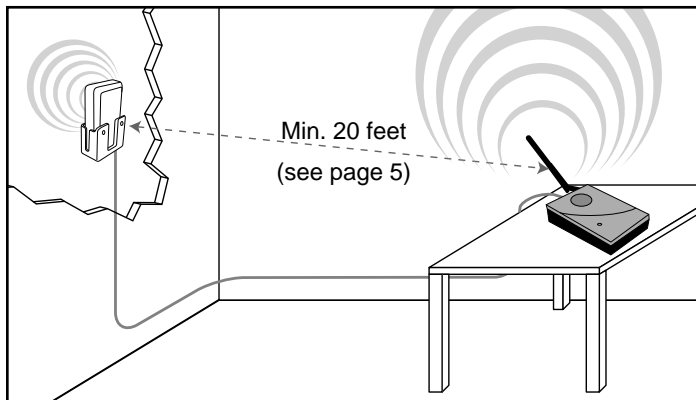

Figure 8

2. Using the cradle as a template, position it on the wall in the desired location and mark the screw holes with a pencil.
3. Drill two holes where marked, using a 3/16-inch bit and insert the screw anchors.
4. Line up the holes in the cradle with the screw anchors and mount the cradle to the wall using two screws and two washers (see Figure 9). Tighten the screws with a Phillips-head screwdriver.
5. Insert the antenna into the cradle **with the Wilson insignia facing in the direction of the cell tower**. The cable connection should protrude through the bottom of the cradle.
6. Connect the supplied coax cable to the antenna. Route the cable as desired to where the amplifier will be located. Depending on the distance between the amplifier and antenna, you may need one or both lengths of the supplied cable. If you use both, connect them together with the supplied cable connector.

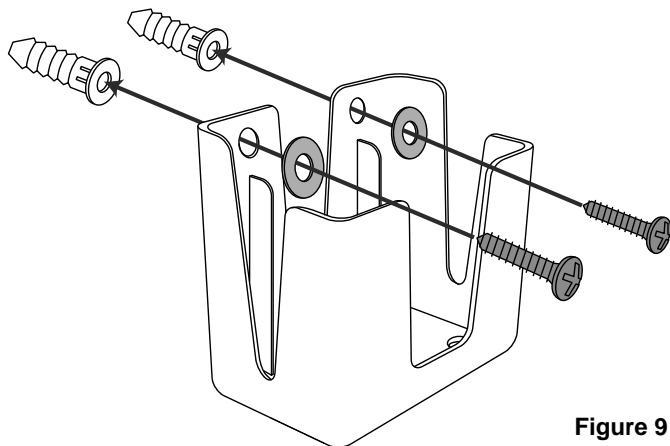

Figure 9



Coax Cable



Cable Connector

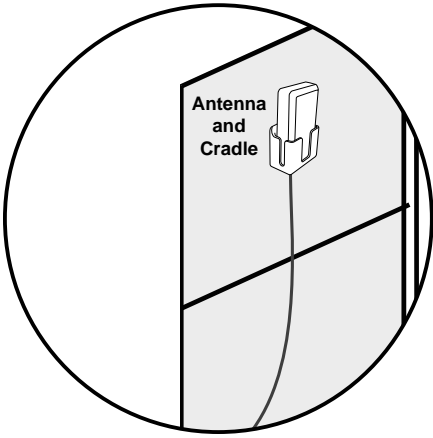

## Inside Window Mount (Packet C)

1. Select a location on the inside of the window as high as possible and at least 20 feet from where the amplifier will be located (see Figure 10).



**Warning: RF Safety:** The cradle antenna, when used with the included cable, must have a separation distance of at least 8 inches from all persons. If the cable is shortened, or if a different type of cable is used, or if a different antenna is used, consult with Wilson Technical Support to verify that the planned installation is safe. Call 866-294-1660 or 435-673-5021, or email [tech@wilsonelectronics.com](mailto:tech@wilsonelectronics.com).

2. Clean the area on the glass with the supplied alcohol prep pad.
- 3a. If you plan to remove or relocate the cradle antenna at some point, use the suction cups provided in Packet A. Using a twisting motion, press the suction cups into the two holes on the antenna cradle (see Figure 11), then press the cradle onto the glass at the desired location.

- 3b. For a more permanent installation, use the double-sided adhesive strip. Cut the strip as shown in Figure 12. Peel the backing from one side of the strip and place it on the back of the cradle (see Figure 13). Peel the backing from the other side of the strip and press the cradle onto the glass at the desired location.

4. Insert the antenna into the cradle **with the Wilson insignia facing in the direction of the cell tower**. The cable connection should protrude through the bottom of the cradle.
5. Connect the supplied coax cable to the antenna and route the cable as desired to where the amplifier will be located. Depending on the distance between the amplifier and antenna, you may need one or both lengths of the supplied cable. If you use both, connect them together with the supplied cable connector.

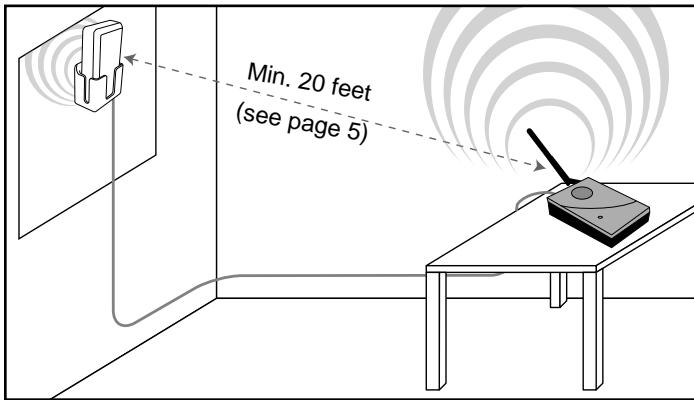
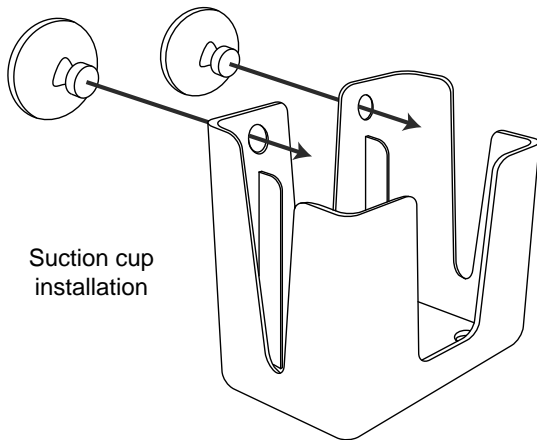

Figure 10



Suction cup installation

Figure 11

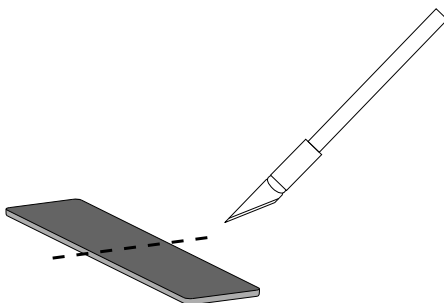

Figure 12

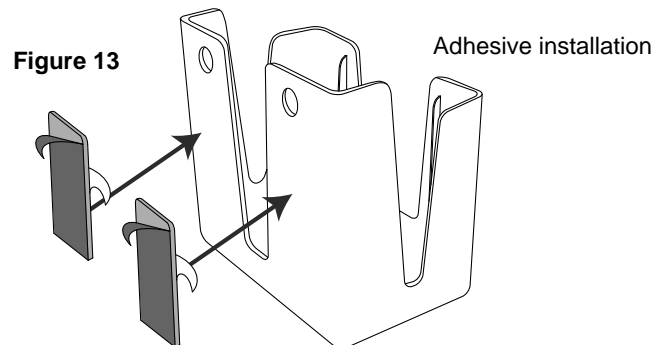

Figure 13

Adhesive installation

## Installing the Amplifier Unit

**Warning:** The amplifier unit is designed for use in an indoor, temperature-controlled environment (less than 100 degrees Fahrenheit). It is not intended for use in attics or similar locations subject to temperatures in excess of that range.

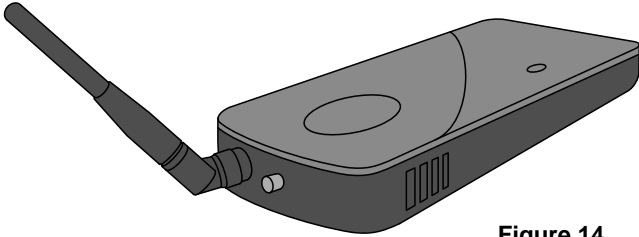

Figure 14

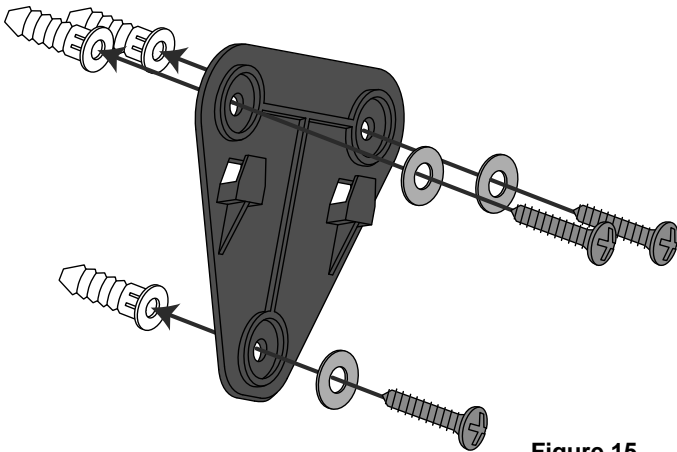

Figure 15

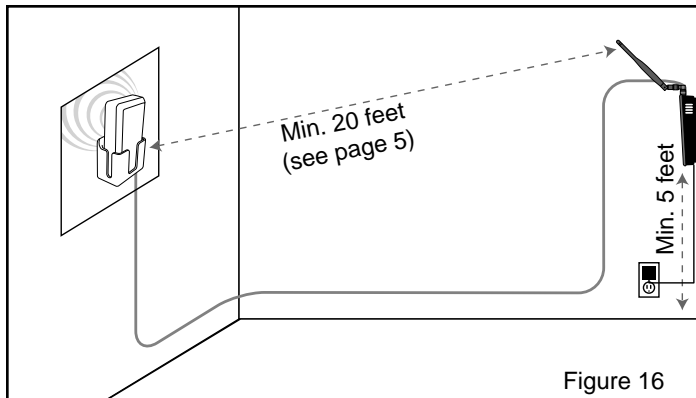

Figure 16

**Warning:** The on-board antenna must have a separation distance from all persons that is at least 8 inches.

**Warning:** Connecting the amplifier directly to the cell phone with use of an adapter will damage the cell phone.

### Desk or Table Mount

1. Attach the on-board antenna by screwing it onto the threaded connector on the amplifier. Position the antenna at a 45-degree angle by adjusting it on its base (see Figure 14). Note: the on-board antenna may be positioned vertically; however, this will require greater separation from the cradle antenna (see Page 5).
2. Place the amplifier on a desk, table or similar surface where you have routed the coax cable.

**Warning: RF Safety:** The amplifier must be placed so that its on-board antenna has a separation distance of at least 8 inches from all persons.

3. Attach the cable to the connector on the amplifier.

### Wall Mount

1. Attach the on-board antenna by screwing it onto the threaded connector on the amplifier (see Figure 14).
2. Position the triangular wall-mount bracket at the desired spot on the wall, at least 5 feet up from the floor and away from any other amplifier or antenna.

**Warning: RF Safety:** The amplifier must be placed so that its on-board antenna has a separation distance of at least 8 inches from all persons.

3. Using the bracket as a template, mark the locations for the screws using a pencil.
4. Drill the holes, using a 3/16-inch drill bit and insert the screw anchors. **Note:** if you are not using the wall-mount hardware in Packet B for the cradle antenna, you can use it for the amplifier. Otherwise, you will need to purchase three screws, washers and anchors.
5. Align the triangular bracket with the screw anchors (Figure 15) and attach it with screws and washers. Tighten the screws with a Phillips-head screwdriver.
6. Slide the amplifier onto the bracket. Position the antenna at a 45-degree angle for best performance (see Figure 16).
7. Attach the cable to the connector on the amplifier.

## Powering Up the Amplifier

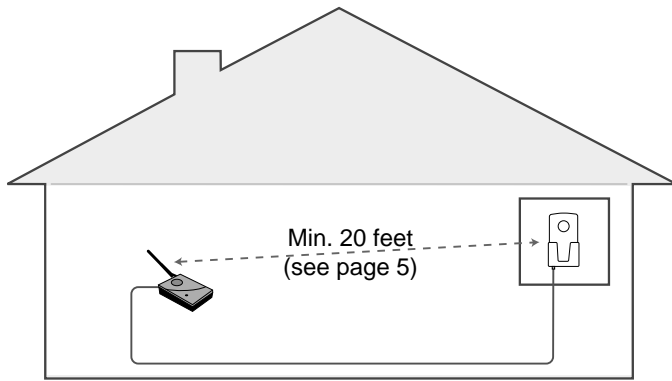



Figure 17

1. Ensure that the distance between the amplifier and the cell phone or cellular data card does not exceed 4 feet.
2. **Important:** Ensure that any other cell phones and cellular data cards are turned off unless they are at least twice the distance from the amplifier than the desired unit.
3. Ensure that the distance between the on-board antenna and the cradle antenna is a minimum of 20 feet (see Figure 17). If you are using a different antenna configuration, see the separation guidelines for your specific antennas or call Wilson's Technical Support department at 866-294-1660 or 435-673-5021.
4. Ensure that the coax cable is attached to the amplifier and the cradle antenna before powering up the amplifier.
5. Plug the power supply into the amplifier input marked "Power" (carefully, to avoid damaging the center pin) and then into a wall outlet.

 **Warning:** Verify that the on-board antenna is attached and that the cable from the cradle antenna is connected before powering up the amplifier.

 **Warning:** Use only the power supply provided in this package. Use of a non-Wilson product may damage your equipment.





**GREEN:**

**ORANGE:**

**ORANGE:**

**RED:**

## Warnings and Recommendations

-  **Warning:** Connecting the amplifier directly to the cell phone with use of an adapter will damage the cell phone.
-  **Warning:** Attach the on-board antenna and connect the cradle antenna before powering up the amplifier.
-  **Warning:** Use only the power supply provided in this package. Use of a non-Wilson product may damage your equipment.
-  **Warning:** **RF Safety:** A minimum separation distance of at least 8 inches must be maintained between the antennas supplied with this amplifier and all persons. A different antenna may be used in place of the on-board antenna, provided that its gain does not exceed 15 dBi and it is separated by at least 8 inches from all persons. Antennas **outside of the building** may have gains as high as 15 dBi, provided that a separation distance of at least 30 inches is maintained between the antennas and all persons. Use of antennas with higher than the above maximum gains and/or closer to people than the specified minimum distance is in violation of FCC regulations for which the offender is fully liable.
-  **Warning:** Always operate cell phone at least three feet from the on-board antenna.

## Frequently Asked Questions

*What kind of improvement in cell phone performance can I expect with the SignalBoost DT?*

The SignalBoost DT's performance will depend somewhat on the strength of the cellular signal outside your home or building. However, if you install the SignalBoost DT in accordance with the instructions in this guide, you can expect a significant improvement in your ability to use your cell phone or cellular data card indoors.

*Where should I install my SignalBoost DT to get the best coverage?*

You should install the amplifier in the area where you most need an improved signal. The farther you are from the amplifier, the less improvement you will experience. It is also important to install the cradle antenna in a location where you have the strongest outside signal (see page 4). Also keep in mind the distance between the amplifier and the cradle antenna. You'll need at least 20 feet of separation to prevent the start of oscillation, but you'll probably want to stay within the 50-foot length of the coax cable. (Additional cable and the necessary connectors are available from your Wilson dealer, but using more cable will result in some signal loss.)

*Instead of placing the amplifier on a desk or table, I'd rather attach it to a wall – will it still work OK?*

Yes! Your SignalBoost DT comes with a triangular wall bracket that allows you to mount the amplifier on a wall. Just be sure that the on-board antenna is positioned at a 45-degree angle (see page 9).

*What color should the indicator light be showing?*

Once the amplifier is powered up, the indicator light should be green during normal operation.

*The amplifier light is red – what does that mean?*

When the light is red, the amplifier has shut down due to oscillation between the on-board antenna and the cradle antenna. Increase the distance between the two antennas then remove and reinsert the power cable to reset the amplifier (see page 5).

*I have a Nextel phone – will the SignalBoost DT boost that signal?*

The SignalBoost DT is designed to work with both the Cellular (800 MHz) and PCS (1900 MHz) bands, but not the iDEN/Nextel frequency. Wilson offers specific amplifiers for iDEN/Nextel users. Visit [www.wilsonelectronics.com](http://www.wilsonelectronics.com) for details.

*Can I use my own cable for my installation?*

The low-loss RG6 cable included with your product has been specifically selected for the SignalBoost DT. Use of another type or longer length of cable will likely degrade the system's performance.

*Can I use different antennas than the ones supplied in the box?*

Yes! While the SignalBoost DT is designed to give you reliable signal improvement with the included antennas, Wilson offers a variety of optional antennas and accessories that enable you to customize your SignalBoost DT to your specific needs. Visit [www.wilsonelectronics.com](http://www.wilsonelectronics.com) for details.

*There are frequently several people using cell phones in my office at the same time – will the SignalBoost DT improve the signal for all of them?*

Absolutely! The SignalBoost DT is designed to support multiple users simultaneously (within the range of the on-board antenna).

*I have installed the system but I don't have the coverage I need – what can I do?*

See the section below.

### **For Weak Areas with Insufficient Signal**

In areas with particularly weak outside signals, additional coverage can be obtained by removing the on-board antenna and replacing it with a high-gain inside panel antenna (Wilson part #301147). This antenna (which includes cable) can double the inside coverage area. (See Figure 18.)

**Figure 18**

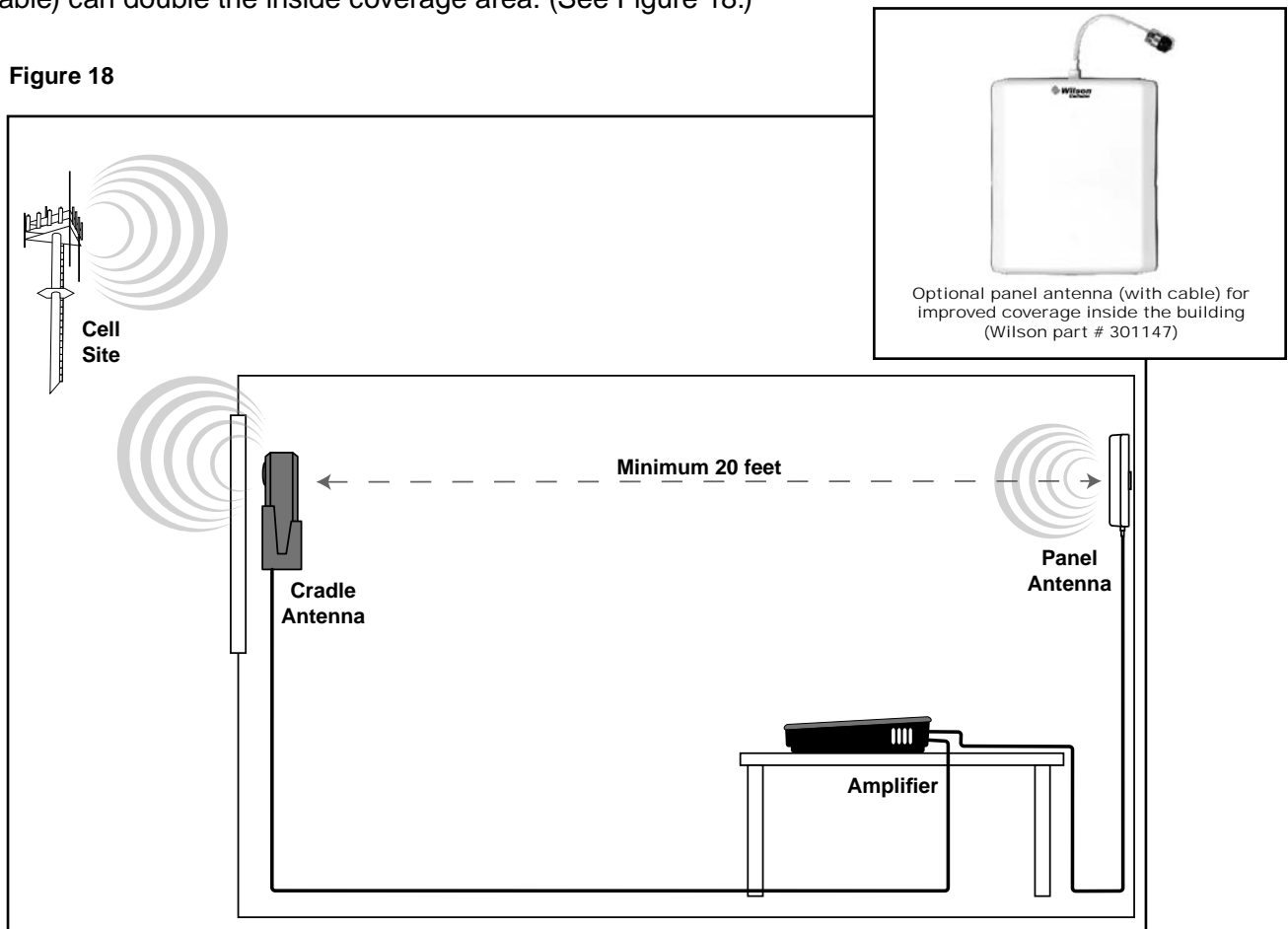

*I have questions about my installation – where can I get some help?*

Wilson's Technical Support representatives are just a phone call or email away. Call 866-294-1660 or 435-673-5021, or send an email to [tech@wilsonelectronics.com](mailto:tech@wilsonelectronics.com).

## Amplifier Specifications

		Dual-Band Wireless 800/1900 MHz Specifications	
<b>Model Number</b>	271247		
<b>Connectors</b>	To onboard antenna: TNC Female	To cradle antenna: F Female	
<b>Impedance</b>	Onboard antenna: 50 ohms	Cradle antenna: 75 ohms	
<b>Dimensions</b>	6.2 x 4.2 x 1.5 inch (15.7 x 10.7 x 3.8 cm)		
<b>Weight</b>	0.64 lbs (0.29 kg)		
<b>Frequency</b>	824-894 MHz / 1850-1990 MHz		
<b><sup>1</sup>Passband Gain (nominal)</b>			
	800 MHz	55 dB	
	1900 MHz	55 dB	
<b><sup>2</sup>20 dB Bandwidth (nominal)</b>			
	800 MHz	32 MHz	
	1900 MHz	74 MHz	
<b>Power output for single cell phone (uplink)</b>			
	800 MHz	1900 MHz	
	CDMA	29.9 dBm	29.7 dBm
	GSM	28.8 dBm	31.1 dBm
	EDGE	30.8 dBm	31.1 dBm
	AMPS	29.5 dBm	
<b>Power output for single received channel (downlink)</b>			
	800 MHz	1900 MHz	
	CDMA	15.6 dBm	12.5 dBm
	GSM	11.7 dBm	11.6 dBm
	EDGE	12.4 dBm	9.5 dBm
	AMPS	12.3 dBm	
<b><sup>3</sup>Power output for multiple received channels (uplink)</b>			
		Maximum Power	
The maximum power is reduced by the number of channels:	Number of channels	800 MHz	1900 MHz
	2	22.6 dBm	23.2 dBm
	3	19.0 dBm	19.7 dBm
	4	16.5 dBm	17.2 dBm
	5	14.6 dBm	15.3 dBm
	6	13.0 dBm	13.7 dBm
<b><sup>4</sup>Power output for multiple received channels (downlink)</b>			
		Maximum Power	
The maximum power is reduced by the number of channels:	Number of channels	800 MHz	1900 MHz
	2	13.4 dBm	14.3 dBm
	3	9.9 dBm	10.7 dBm
	4	7.4 dBm	8.2 dBm
	5	5.4 dBm	6.3 dBm
	6	3.8 dBm	4.7 dBm
<b>Noise Figure (typical)</b>	3.5 dB nominal		
<b>Isolation (uplink/downlink)</b>	> 90 dB		
<b>Power Requirements</b>	110-240 V AC, 50-60 Hz, 8 W		

Notes:

1. Nominal gain is the maximum gain at any frequency in the passband.
2. Nominal bandwidth is the difference between two frequencies that are adjacent to the passband where the amplification is 20 dB lower than the passband amplification. One of the frequencies is lower than the passband and the other is higher.
3. The Manufacturer's rated output power of this equipment is for single carrier operation. For situations when multiple carrier signals are present, the rating would have to be reduced by 3.5 dB, especially where the output signal is re-radiated and can cause interference to adjacent band users. This power reduction is to be by means of input power or gain reduction and not by an attenuator at the output of the device.
4. The maximum power for 2 or more simultaneous signals will be reduced by 6 dB every time the number of signals is doubled.

### **30-Day Money-Back Guarantee**

All Wilson Electronics products are protected by Wilson's 30-day money-back guarantee. If for any reason the performance of any product is not acceptable, simply return the product directly to the reseller with a dated proof of purchase.

### **1-Year Warranty**

Wilson Electronics amplifiers are warranted for one (1) year against defects in workmanship and/or materials. Warranty cases may be resolved by returning the product directly to the reseller with a dated proof of purchase.

Amplifiers may also be returned directly to the manufacturer at the consumer's expense, with a dated proof of purchase and a Returned Material Authorization (RMA) number supplied by Wilson Electronics. Wilson shall, at its option, either repair or replace the product. Wilson Electronics will pay for delivery of the repaired or replaced product back to the original consumer.

This warranty does not apply to any amplifiers determined by Wilson Electronics to have been subjected to misuse, abuse, neglect, or mishandling that alters or damages physical or electronic properties.

RMA numbers may be obtained by phoning Technical Support at 866-294-1660.

### **Installation Instructions for the Following Wilson Amplifier:**

#### **SignalBoost DT Dual-Band Cellular/PCS Amplifier**

Model # 271247, Part # 801247

FCC ID: PWO271247SB      IC: 4726A-271247SB

The term "IC" before the radio certification number only signifies that Industry Canada technical specifications were met.

Operation is subject to the following two conditions: (1) This device may not cause interference and (2) this device must accept any interference, including interference that may cause undesired operation of this device.

Disclaimer: The information provided by Wilson Electronics, Inc. is believed to be complete and accurate. However, no responsibility is assumed by Wilson Electronics, Inc. for any business or personal losses arising from its use, or for any infringements of patents or other rights of third parties that may result from its use.

Copyright © 2007 Wilson Electronics, Inc. All rights reserved.



## **About Wilson Electronics**

Wilson Electronics, Inc., a leader in the wireless communications industry for over 40 years, designs and manufactures amplifiers, antennas and related components that significantly improve cellular telephone signal reception and transmission in a variety of mobile, small building and large building applications.

With extensive experience in antenna and amplifier research and design, the company's engineering team uses a state-of-the-art testing laboratory, including an anechoic chamber and network analyzers, to fine-tune antenna designs and performance. For its amplifiers, Wilson uses a double electrically insulated RF enclosure and cell site simulators for compliance testing.

Wilson amplifiers feature patent-pending Smart Technology™ that enables them to automatically adjust their power based on cell site requirements. By detecting and preventing oscillation, signal overload and interference with other users, these Smart Technology™ amplifiers improve network cell phone areas without compromising carrier systems.

All products are engineered and assembled in the company's 50,000-square-foot headquarters in St. George, Utah. Wilson has product dealers in all 50 states and in countries around the world.



3301 East Deseret Drive  
St. George, Utah 84770  
[www.wilsonelectronics.com](http://www.wilsonelectronics.com)  
Toll-Free: 866-294-1660  
Fax: 435-656-2432